

CT XTRA RANGE

Salamander Pumps 

An innovative range of single and twin ended shower pumps. The CT Xtra range raises the bar for all other 'entry level' shower pumps to follow. Designed to quietly and efficiently boost the hot and cold water supplies to the thermostatic or manual mixer valves and are suitable for a wide range of shower types and heads, these pumps will increase flow to any type of shower making them the best value for money pumps available.



Features

- 1.5, 2.0, 2.2 Bar (CT85 Xtra) performance options
 - Compact size
 - Very quiet
 - Compact Salamander exclusive shaft seal
 - Continuously rated
 - Fully automatic
 - 15mm push fit flexible hoses
 - Pre-wired with 1.25 metre power cable
 - Anti-vibration feet
 - 3 year warranty
-
- **UK Specification:** Supplied with 15mm pushfit x $\frac{3}{4}$ anti-vibration flexible hoses.
 - **ROI Specification:** Supplied with 15mm pushfit x $\frac{3}{4}$ anti-vibration flexible hoses.

Pressure vs Flow

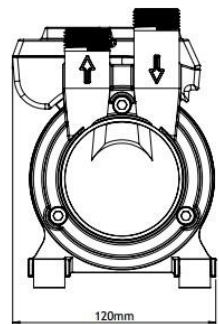
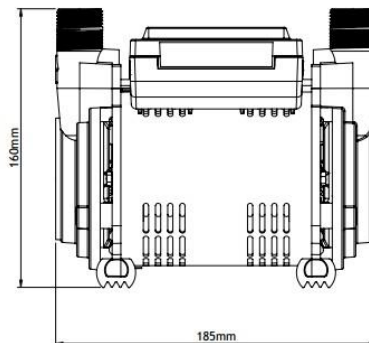
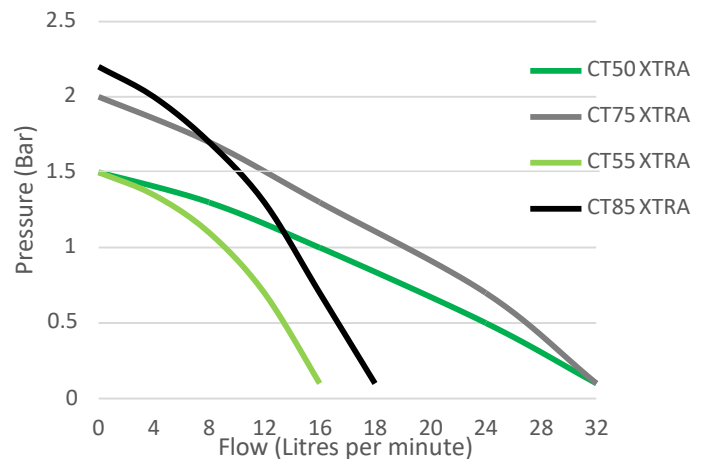

We're here to help before, during and after installation. Get in touch for guidance by calling our Pumpwise team or email tech@salamanderpumps.co.uk

Pumpwise
0191 516 2002

CT XTRA Technical Specification

Pump Model		CT50XTRA	CT75XTRA	CT55XTRA	CT85XTRA
General	Guarantee	3 years			
	WRAS approval	1309001			
Features	Pump Type	Regenerative			
	Mechanical seal	Nitrile/ Carbon/ Ceramic			
	Anti-vibration feet	✓	✓	✓	✓
	Inlet Isolator(s) – only on '+' models	✓	✓	✓	✓
	Flexible Hoses	4	4	2	2
Performance	Pressure @ 16lpm (8lpm for singles)	1.0 Bar	1.3 Bar	1.1 Bar	1.7 Bar
	Pressure @ 8lpm (4lpm for singles)	1.3 Bar	1.7 Bar	1.35 Bar	2.0 Bar
	Pressure @ Closed Head	1.5 Bar	2.0 Bar	1.5 Bar	2.2 Bar
	Maximum Water Temperature	65°C			
Connections	Pump connections	¾" BSP			
Flexible hoses	Connections (UK Model)	¾" Female x 15mm Push-Fit x 195mm long			
	Connections (ROI Model)	¾" Female x 21mm Push-Fit x 195mm long			
Motor	Type	A.C Induction Motor			
	Duty Rating	Continuously Rated			
Electrical	Power supply	230 V			
	Current (full load)	1.97 Amps	2.05 Amps	1.26 Amps	1.07 Amps
	Power consumption	455 Watts	484 Watts	273 Watts	246 Watts
	Fuse rating	3 Amps			
	Power cable (pre-wired)	1.5 metres			
Physical	Enclosure Protection (IP Rating)	IPX2			
	Length	185mm			
	Width	120mm			
	Height (Excluding Hoses)	160mm			
	Weight (Excluding Hoses)	3.9kg	3.9 kg	3.8kg	3.8kg

Why Choose a CT **XTRA**?



SOLID STATE SWITCHING

Solid State Switching is the reliable and robust pump activation system used within our products. Where many other shower pump designs rely upon moving parts to activate their pumps, the new Solid State Switching (S3) from Salamander uses an electronic switch that has no moving parts, thus improving reliability, sensitivity, and product life.



NOISE/VIBRATION REDUCTION

Noise/Vibration Reduction has been achieved in Salamander products through design innovation. This includes noise and vibration reducing feet which work in alignment with the natural vibration of the motor.

Also, the materials used in the integrated end shield within the pump (MPI) are capable of dampening the vibration of the rotating parts reducing the noise even further.



MOTOR PUMP INTEGRATION



Patent GB2465392B protects Salamanders design of an efficient waterway which combines to create an integrated volute and motor mounting. This makes the pump a lot more compact in size. This means that it is able to be operated in smaller areas and is easily repositioned for installers to fit in tight spaces.

FR8 SEAL

Salamanders exclusive compact PTFE seal which eliminates shaft seal stiction and mechanical seal leakage. This prolongs the life of the product and ensures that the owner of the pump has an ultra-efficient product.