

Installation and warranty guide for TankBoost range



This document should be given to the end user and retained for future reference. Should you need to contact Salamander Pumps you will need the below information.



ISSUE 30
MAY 2024

Safety, installation & warranty guide

Important – read this first!

Safety in Operation

These appliances are not intended for use by persons (including children) with reduced physical, sensory or mental capabilities, or lack of experience and knowledge, unless they have been given supervision or instruction concerning use of the appliance in a safe way by a person responsible for their safety and understand the hazards involved.

Children should be supervised to ensure that they do not play with the appliance.

Cleaning and user maintenance shall not be made by children without supervision.

If the supply cord is damaged, it must be replaced by the manufacturer, its service agent, or similarly qualified person in order to avoid a hazard.

The installation must be carried out to comply with the latest Water Supply Regulations, Wiring/Electrical Regulations, Building Regulations and local byelaws.

Correct installation is the guarantee of safety and a trouble free system. It is therefore important to read these instructions thoroughly and ensure you comply with them. Incorrect fitting could cause serious injury, death, property damage and invalidate the warranty.

If your installation is complicated or you have any questions please consult PUMPWISE TECHNICAL HELPLINE on 0191 516 2002 (01844-3212 ROI)

We encourage installers to consult the PumpWise helpline, where our technical team can give you first-rate advice regarding installation.

The warranty for these products can be registered by calling PumpWise on the number above or by visiting : www.salamanderpumps.co.uk

Do not unpack until ready to use. Store product upright and in a dry, frost free location.

This product must be installed by a qualified/competent person. Please leave this installation guide with the customer for reference to maintenance and safety information.

Thank you for choosing Salamander Pumps

Contents

Product Description	4
Product Diagram	4
Dimensions	5
Installation Notes	6
General Plumbing	6
Typical Installation Diagrams	7
Electrical Installation	8
Commissioning	8
Maintenance	9
Standards & Approvals	9
Technical Specification	10
Troubleshooting	11
Control Unit Display Codes	12
Factory Reset (Control Unit)	13
Additional Water Storage Tanks	14
CAT5 TankBoost	15
WEEE Directive	16
PumpWise and Warranty	16
Warranty	17
Terms and Conditions	18

Register your warranty

Online at: www.salamanderpumps.co.uk

By phone: 0191 516 2002



Product Description

TankBoost is a single unit solution for domestic situations with low incoming mains water pressure or flow, and/or a restrictive incoming main water pipe (typically lead mains). TankBoost can deliver up to 80lpm of water at up to 3 bar pressure. The unit consists of a submersible pump within a potable water tank, with an integrated pressure vessel.

TankBoost is available in 4 different tank sizes (100L, 200L, 350L & 450L) depending on

the volume of stored water required for the installation site. Additional storage tanks are available to link to the original unit to increase the volume of stored water. NOTE: the additional storage tank size must match the original unit size to avoid any water imbalance.

CAT5 option available for all tank sizes-incorporating a weir type overflow, with a type AB air gap, providing fluid category 5 backflow protection.

Performance curve, applicable to all TankBoost pumped models.

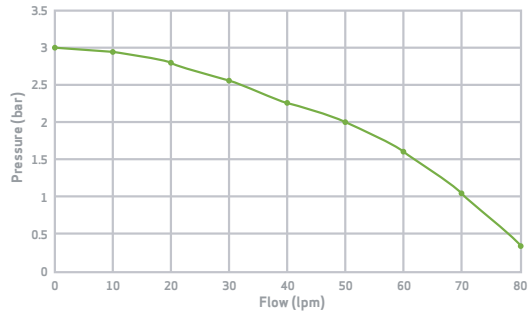

Product Diagram

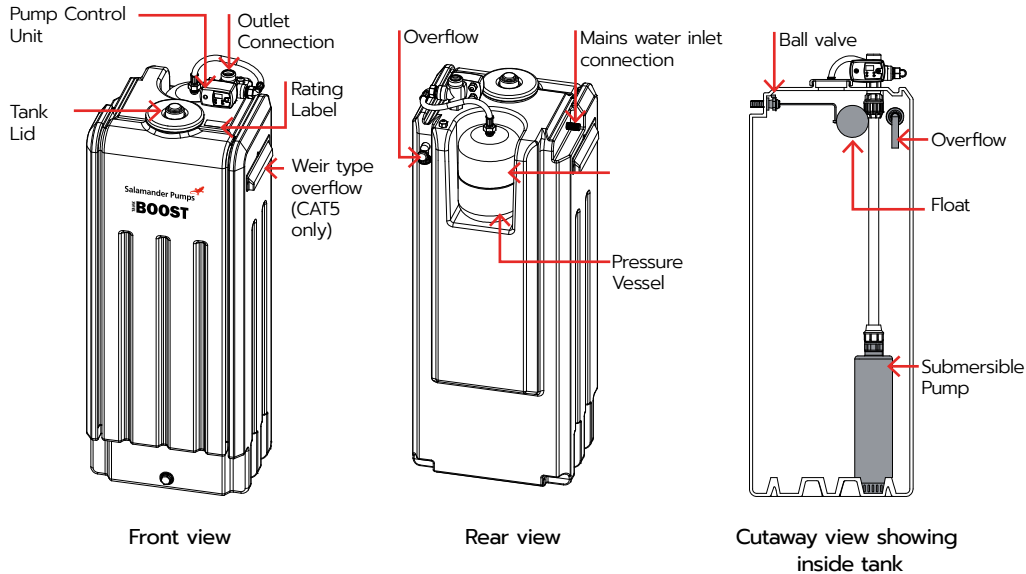

TankBoost Dimensions

All dimensions are in mm.

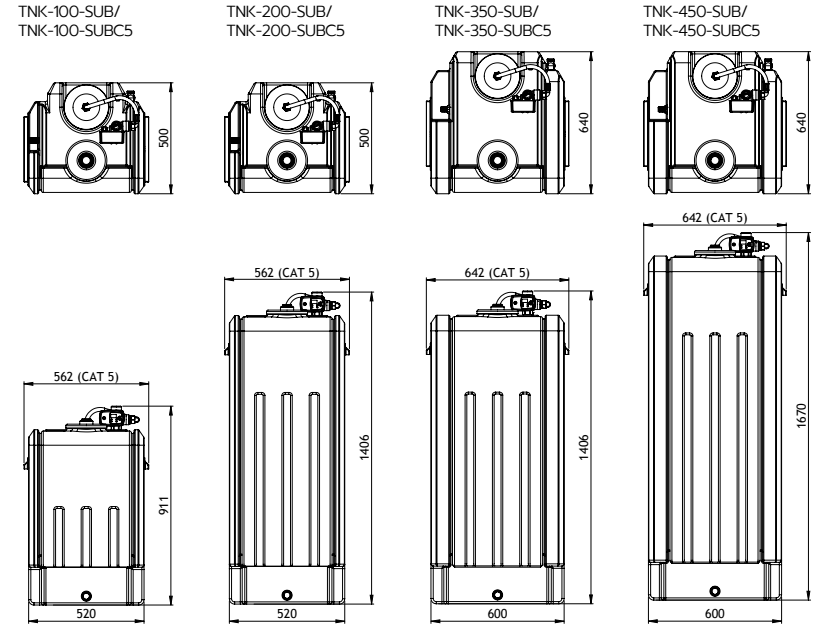

Additional Storage Units

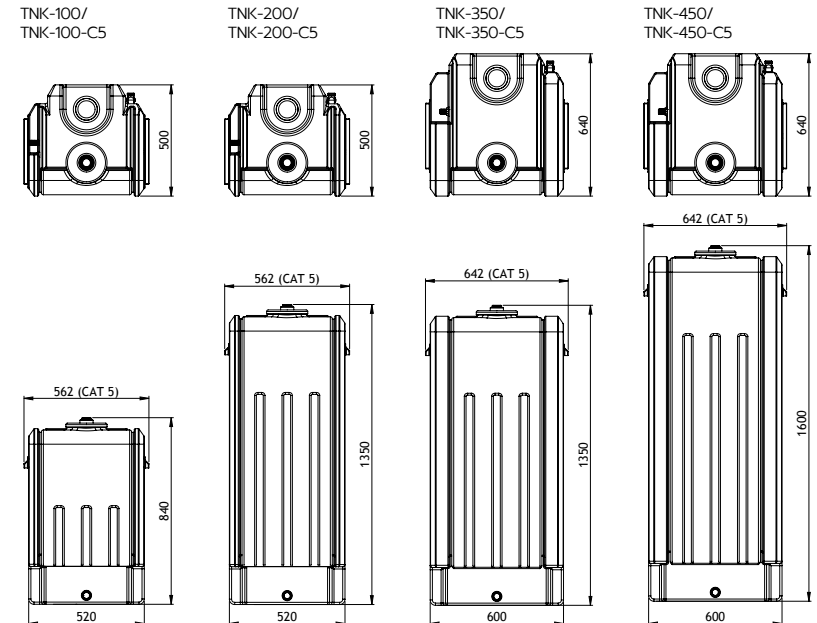

Installation Notes

Location

- The floor/mounting surface (supporting TankBoost) must be flat and level, fully supporting the unit. It must be able to withstand the maximum full weight of the TankBoost unit (please refer to the technical specification for the weights of each unit). Additional supports should be added to the support surface if required.
- Once a suitable location has been identified, the unit should be removed from the packaging and inspected for any damage.
- Carefully move the unit into position.
- The connection to the TankBoost inlet should be made after the supply to a drinking water taps, such as a kitchen tap.
- Ensure that the stored volume of water remains above 4°C and below 20°C to avoid bacterial growth and to protect the unit from frost. Note: Insulation may need to be applied to the outside of the tank to achieve this.
- TankBoost is to be installed where light is excluded.
- To ensure the tank cannot tip, we recommend the unit is fixed to a suitable supporting wall.
- Consider sufficient space is left above the TankBoost unit for maintenance/service access.
- No pump is silent – consider the residual noise, from the unit, around your installation. Insulation jackets and foam mats can be used to dampen any noise or vibrations.

General Plumbing

- The existing domestic plumbing should have a single outlet taken before the inlet to TankBoost to allow for a supply of fresh drinking water (typically the kitchen sink).
- To protect the unit from bacterial growth and frost, ensure the unit is located and sufficiently insulated in an area where the stored water temperature remains between 4°C-20°C.
- Installation must comply with the relevant water regulations or local byelaws.
- In line with good plumbing practice and water regulations, ensure that a double check valve has been fitted directly after the mains stop tap to the house.
- Earth continuity must be maintained on the pipework.
- Good plumbing practice is to fit full bore isolating valves into the inlet and outlet pipe work of TankBoost to facilitate service and removal of the unit. Consult the installation diagram for more information.
- Never fit to hot water pipework
- Never use jointing compounds, Boss White, hemp, or steel wool.
- Solder fluxes must not come into contact with any part of the unit.
- All associated pipework must be thoroughly flushed before making final connections to the TankBoost unit.
- 28mm pipework is recommended from the outlet of the unit to allow maximum flow rate. Smaller diameter pipes may result in reduced flow rates and general product performance.
- All pipework to and from the TankBoost unit should be supported with pipe clips.
- If the supply is known to be lime/calcium (hard) water, fit extra filtration before the unit. Always consult filter manufacturer's literature for correct installation.
- It is advisable to fit a filter before the inlet to the unit.
- 22mm pipework should be fitted to the overflow at the rear of the tank and traced to the nearest drain or outdoor location to prevent flooding in case of failure.
- A tundish can be added to the overflow pipework to allow any overflow to be visible.
- Tank may flex slightly when fully filled and is built to accommodate this.
- If necessary an additional drain-off point can be added to the tank at the tank link connector position.

Typical Installation Diagrams

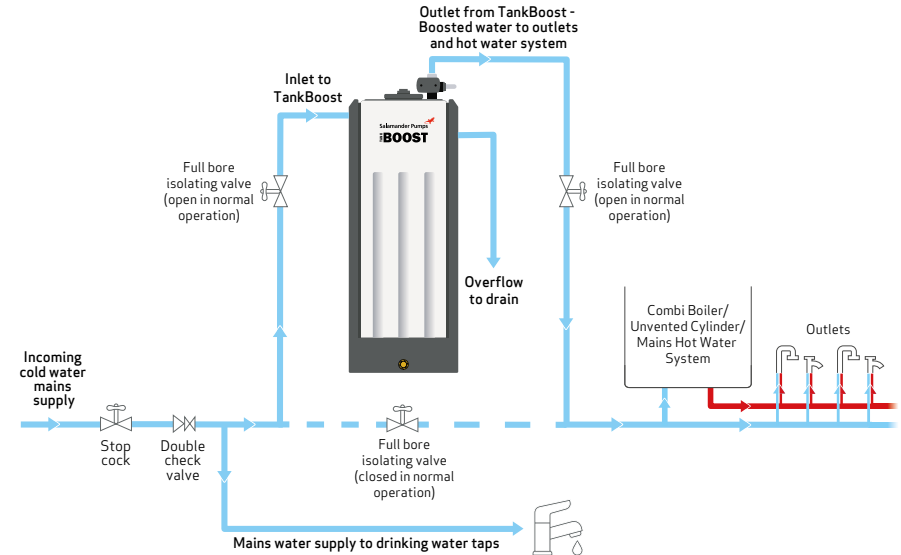

Note: In all instances, the installation must comply with the latest water, electrical and building regulations

Typical Installation for TankBoost with Additional Storage Unit

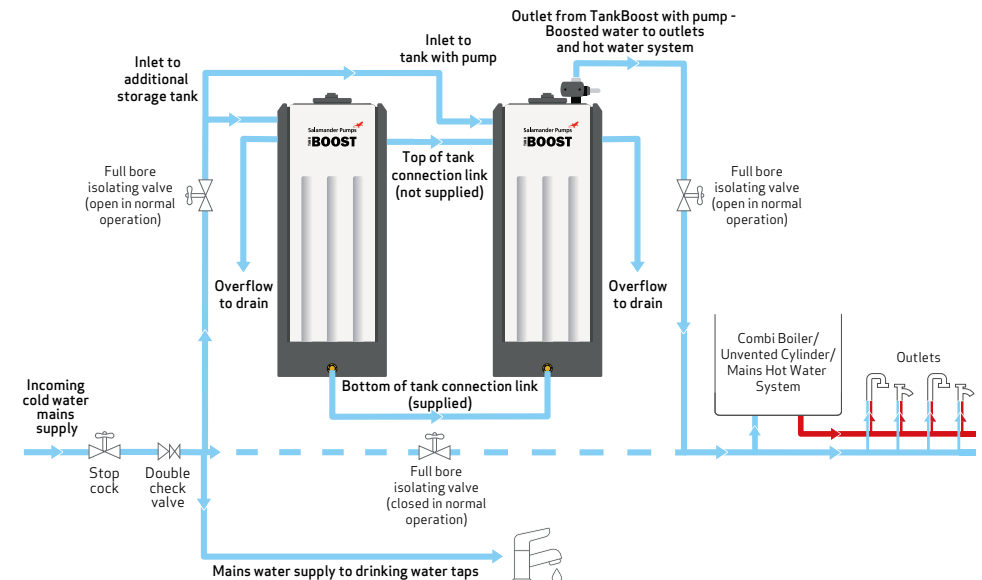

Additional storage tanks must be the same capacity as the main TankBoost unit. The tanks must be located next to each other and on the same level. The total volume of stored water must not be more than will be used in a single day. The supplied tank connector kit should be used to link the tanks at the bottom. An additional connection between the tanks should be made at the top (note: not supplied).

Electrical Installation

- TankBoost must be connected to the electrical supply using the mains cable, wired to a UK 3-pin plug or fused spur (with a 5A fuse).
- The supply cord should be cut down to a suitable length to avoid excess cable. Any excess cable must not be coiled.
- This must be an accessible connection that has been installed in compliance with IET Wiring Regulations.
- The connection must be earthed via the supply cord and the circuit must be suitably RCD protected. All pipe work must be cross bonded in accordance with the IET Regulations.
- If the supply cord is damaged, it must be replaced by the manufacturer, its service agent, or similarly qualified person in order to avoid a hazard.
- Water should not be allowed to come into contact with the electrical connection.
- If the unit is to be installed in a loft, garage, outbuilding or other location where there is a risk of water ingress or condensation to the connection, an appropriately IP rated socket must be used.
- The mains lead wires in this unit are coloured as follows:
Brown = Live
Blue = Neutral
Green & Yellow = Earth

Commissioning

Before you make electrical supply to unit:

1. Flush the inlet pipework with water, before connecting to the tank, then turn off mains water supply at the stop tap.
2. Connect inlet pipework to the unit.
3. Check that all isolating valves are open (except mains bypass valve which should be closed) - see typical installation diagrams.
4. Turn mains water on at the stop tap to fully fill the tank with water. Inlet flow will stop when shut off by the float valve.
5. Check there is at least 25mm gap between the level of the water when full and where the water exits the inlet valve. Adjust the float position if necessary. For CAT5 variants, refer to CAT5 TankBoost section for relevant air gap and float position guidance.
6. Inspect inlet pipework connected to the unit for leaks.
7. Open all the water outlets BEFORE electrically switching the pump on. It is important to ensure all air can be discharged through the system (all the hot and cold outlets on a whole house application).
8. Switch on electrical supply to TankBoost (the screen will display 'OFF').
9. Press the power button on the control unit, the pump will automatically start and begin pumping water.
10. Screen will display the current pressure of the system. Note: It may take a few seconds for the pump to clear any air locks and begin pumping water. It may also be necessary to stop and start the pump a few times to allow all air to be discharged. This can be done by pressing the 'Enter' button to switch off the pump and then pressing it again to turn the pump on.
11. If TankBoost does not activate, please refer to the trouble shooting section of these application notes.
12. Close all household outlets.
13. Check that pump turns off (this may take a few seconds while the pump pressurises the system).
14. Check for leaks while the system is pressurised.
15. During normal operation, it is not necessary to adjust the control unit.

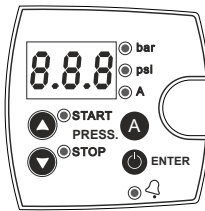

Maintenance

Pressure Vessel Pre-Charge

- To maintain optimum performance of the system, the external pressure vessel (supplied with the unit) is pre-charged to 1.5 Bar/22psi. This air pre-charge pressure within the vessel should be maintained with an annual check:
 - Isolate pump electrically.
 - Release system water pressure by opening an outlet on the system and leave the outlet open to drain all remaining water within the system.
 - Lift vessel from it's locator at the rear of the unit.

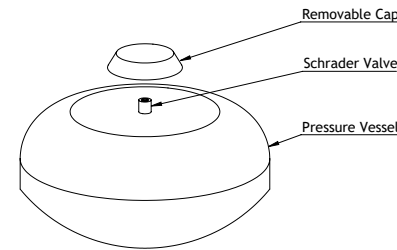

- Remove cap protecting the Schrader valve.
- Check pre-charge at Schrader valve using a tyre pressure gauge.

- If below 1.5 bar/22psi, increase the pressure by injecting air into the vessel via the Schrader valve using a car or bicycle pump. If pressure is greater than 1.5 bar/22psi, remove pressure by depressing the centre of the valve.
- Replace the protective cap and place the vessel into the locator at the rear of the unit.

Stored Water Condition

- As with any stored volume of water, the water temperature needs to remain below 20°C. The quality of stored water will deteriorate with time and temperature. Bacterial growth rates will be higher when the conditions are warm. If the water remains unused for long periods of time, the tank should be drained and flushed through. The tank should be cleaned on an annual basis to protect against bacterial growth. The tank can be drained by isolating the mains water supply to the fill valve and using the pump to empty water out of the tank via the outlets supplied by the unit.
- Regular activation is recommended.

Standards & Approvals

- Water Ingress Protection rating – Pump: IPX8, Controller: IP55
- Complies with European & UK Directives (CE & UKCA)
- EN 60335-1:2002 and EN 60335-2-41:2003 Household and similar electrical appliances – safety (Part 1 General requirements and Part 2-41 Particular requirements for pumps)

Technical Specification

Part Number		TNK-100-SUB (TNK-100-SUBC5)	TNK-200-SUB (TNK-200-SUBC5)	TNK-350-SUB (TNK-350-SUBC5)	TNK-450-SUB (TNK-450-SUBC5)
Warranty		2 years			
Tank size	Useable water (litres)	100 (90)	200 (190)	350 (330)	450 (430)
Dimensions	Height (mm)	911	1406	1406	1670
	Width (mm)	520 (562)	520 (562)	600 (642)	600 (642)
	Depth (mm)	500	500	640	640
Weights	Empty Weight (kg)	37.9	48.7	61.5	67.0
	Filled Weight (kg)	137.9	248.7	411.5	517.0
Pump	Pump Type	Submersible Centrifugal Multi-Stage Pump			
	Pump Body/Impeller	Stainless Steel			
	Enclosure Protection	IPX8			
Electrical	Power Supply	230V, 50Hz			
	Current (Full Load)	4.2A			
	Power Consumption	730W			
	Cable Length	8m (Plug not supplied)			
	Fuse Rating	5A			
Connections	Inlet Connection	1/2" BSP Male			
	Outlet Connection	1" BSP Female			
Performance	Maximum Pressure	3 Bar / 300 kPa			
	Maximum Flow Rate	80lpm			
Typical Noise Rating (dBA)		46.8	44.8	44.4	44.7
Water Temperature		4°C-20°C			
Pressure Vessel		8L Vessel with 1.5 Bar/22psi Air Pre-Charge			

Part Number		TNK-100 (TNK-100-C5)	TNK-200 (TNK-200-C5)	TNK-350 (TNK-350-C5)	TNK-450 (TNK-450-C5)
Warranty		2 years			
Tank size	Useable water (litres)	100 (90)	200 (190)	350 (330)	450 (430)
Dimensions	Height (mm)	840	1350	1350	1600
	Width (mm)	520 (562)	520 (562)	600 (642)	600 (642)
	Depth (mm)	500	500	640	640
Weights	Empty Weight (kg)	22.2	32.9	45.7	51.1
	Filled Weight (kg)	122.2	232.9	395.7	501.1
Connections	Inlet Connection	1/2" BSP Male			
	Linking Connection	Via Linking Kit Supplied			
Water Temperature		4°C - 20°C			

The company operates a policy of continuous development and reserves the right to change any of the specifications of its products without prior notice. All information data and illustrations given in this leaflet may be subject to variation.

Troubleshooting

Scan the qr code for FAQs, videos and articles to help.



Fault	Probable Cause	Recommended Solution
Unit will not start	Electrical	Check power supply. Check fuse. Check circuit breaker. Check display on control unit – refer to fault codes on page 12.
	Inlet/Outlet Connections	Check that the connections are plumbed in the correct way round and all valves are open as per installation diagram. Check that an outlet is open to allow water flow.
	Insufficient stored water	Check that the mains stop tap is open. Check the tank is full before start up. TankBoost stores water. When this has been consumed, the pump will turn off and periodically restart to re-pressurise the system. Wait for the tank to refill before trying further actions. Additional stored water tanks can be connected if required. Total water storage should not exceed estimated system water usage for a 24hr period. Check all isolating valves are open before the unit.
	Pressure vessel pre-charge	Check the pressure vessel pre-charge is set at 1.5Bar/22psi. If not, then adjust the pressure accordingly.
	Restricted outlets	Check there is no blockages or leaks in the pipework being fed by the unit. Check that the system pipework is not airlocked.
Reduced/ Intermittent flow	Restricted outlets	Check there is no blockages or leaks in the pipework being fed by the unit. Check that the system pipework is not airlocked.
	Pressure vessel pre-charge	Check the pressure vessel pre-charge is set at 1.5Bar/22psi. If not, then adjust the pressure accordingly.
Pump starts with all outlets closed	Leak in system	Check for leaks on pipework supplied by the unit.
	Outlet open	Ensure all outlets are fully closed or capped – i.e. no dead legs in pipework.
Unit is noisy	Air in system	Open all outlets and discharge air. Check stored water volume.
	Base site uneven/not level	Ensure unit is fully supported across its entire base. Surface should be flat and level, capable of supporting filled tank weight as per specification table. Unit could be located on top of a carpet/mat to dampen vibrations.
Unit is leaking	Tank has suffered chemical damage	Ensure that no part of the TankBoost unit has come into contact with chemical substance e.g. solder flux.
	Unit exposed to extreme temperature	Ensure adequate frost protection.
	Unit appears to have leaked but not sure	Check any surrounding pipework for leaks. Check condensation build up – large volumes of cold stored water can allow condensation to form on the tank faces. Insulate tank.
Unit does not switch off when all outlets closed	Outlet open	Ensure all outlets are fully closed or capped and check all pipework for leaks.
	Pressure sensor calibration	Contact Salamander Pumps.

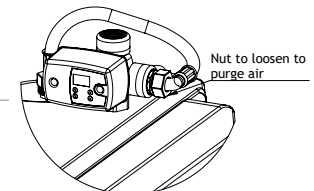

Control Unit Display Codes

In normal operation the control unit displays pressure or current readings directly from the pump in the tank unit. An LED will be lit up to show whether the pressure is being displayed (in bar or psi) or whether current is being displayed (in Amps).

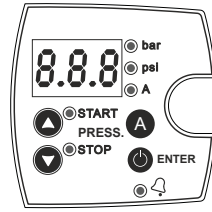

Display Code	Description	System Reaction
A01 / A11	Dry Running / Dry Running by Minimum Pressure	<p>If water level in the tank is low (less than half way up the pump), allow the tank to refill and manually restart the unit by pressing the power/enter button.</p> <p>This error code indicates that the unit will enter into protective shut down to protect the pump.</p> <p>To restart the unit, press the power (enter) button. If the problem persists, please contact Salamander for technical advice.</p> <p>Additional storage tanks can be connected to increase the stored volume of water. Note: total stored water should not exceed estimated usage for a 24 hour period.</p> <p>If there is a level of water in tank (more than halfway up the pump), and the unit is not pumping water to connected outlets (pressure display on control unit reads '0.0'), the system pipework will be airlocked. To clear this press the power (enter) button to turn off the unit. Then, loosen the nut connecting the control unit to the hose to purge the air from the system.</p> <p>Note: there may be some residual water left in the hose. Refasten the nut back onto the control unit, the nut should be tightened finger tight plus a ¼ turn. See diagram for reference.</p>
A02	Current Overload	This code is displayed if the nominal pump current exceeds 4.8A. 4 automatic reset attempts will be performed by the control unit before remaining off until manually reset. During these attempts, the current will be displayed. To restart the unit manually, press the power (enter) button. If the problem persists, please contact Salamander for technical advice.
A04	Fast Cycling (Hammering)	This code is displayed if the system loses pressure instantly when the outlets are closed this will force the pump to switch on and off in a fast cycle. The code is activated when 3 consecutive cycles occur quickly. Check the air pre-charge pressure in the pressure vessel is 15 bar/22psi. To restart the unit, press the power (enter) button. If the problem persists, please contact Salamander for technical advice.
A05	Pressure Transmitter Requires Recalibration	Contact Salamander for technical advice if this code is displayed.

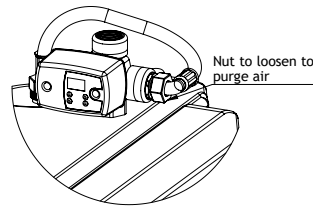

Factory Reset (Control Unit)

Your unit is pre-set with its operating parameters during assembly and testing.

If your unit is failing to operate and if instructed to do so by the Salamander Tech Desk team, please follow these instructions to reset your unit:

- Press and hold ▲, ▼ & ⏻ together until 'nc' flashes on the screen.
- Press ⏻ to display 'E00' flashing on the screen.
- Press ⏻ to display 'ct0' flashing on the screen.
- Press ⏻ to display 'dt0' flashing on the screen.
- Press ⏻ to display 'AE1' flashing on the screen.
- Press ⏻ to display 'Ar0' flashing on the screen.
- Press ⏻ to display 'P0.0' flashing on the screen.
- Press ⏻ to display 'c20' flashing on the screen.
- Press ⏻ to display 'tE0' flashing on the screen.
- Press ⏻ to display 'H00' flashing on the screen.
- Press ⏻ to display 'r50' flashing on the screen.
- Press ▲ to display 'r51' flashing on the screen.
- Press ⏻ to confirm – 'OFF' will display on the screen solid.
- Press and hold 'A' until the display flashes '0.0' – 'A' to the right of the screen will show a green light.
- Press ▲ until you reach 4.8 – press ⏻ to confirm.
- Press and hold ▲ until the display flashes '10' – 'bar' to the right of the screen & 'START PRESS.' will show a green light.
- Press ▲ until you reach 2.0 – press ⏻ to confirm.
- Press and hold ▼ until the display flashes '3.0' – 'bar' to the right of the screen & 'STOP' will show a green light.
- Press ▼ until you reach 2.8 – press ⏻ to confirm.
- The screen will now display 'OFF' – The factory settings have now been restored.
- Press and hold ▲, ▼ & ⏻ together until 'nc' flashes on the screen.
- Press ⏻ to display 'E00' flashing on the screen.
- Press ⏻ to display 'ct0' flashing on the screen.
- Press ⏻ to display 'dt0' flashing on the screen.
- Press ▲ to display 'dt5' flashing on the screen.
- Press ⏻ to display 'AE1' flashing on the screen.
- Press ▲ to display 'AEO' flashing on the screen.
- Press ⏻ to display 'Ar0' flashing on the screen.
- Press ⏻ to display 'P0.0' flashing on the screen.
- Press ▲ to display 'P0.1' flashing on the screen.
- Press ⏻ to display 'c20' flashing on the screen.
- Press ⏻ to display 'tE0' flashing on the screen.
- Press ⏻ to display 'H00' flashing on the screen.
- Press ⏻ to display 'r50' flashing on the screen.
- Press ⏻ to confirm – 'OFF' will display on the screen solid.
- Restart the unit by pressing ⏻.

Factory reset settings

STOP	START	A
2.0	2.8	4.8

Additional Water Storage Tanks

- Additional storage tanks must be the same size as the main pumped unit.
- All tanks must be located on the same level and as close together as possible so as not to restrict movement of water between the tanks.
- Total volume of stored water must not be more than will be used in a single day.
- The supplied tank connector kit should be used to link the tanks at the base.
- An additional link should be made, in 28mm pipework, at the top of the tanks (not supplied). Note: see 'Typical Installation for TankBoost with Additional Storage Unit' diagram. Use a vacuum to remove any debris from inside of the tanks.

1. Remove the inlet float valve from the main tank with the pump/control unit.
2. Insert the supplied bung into the resulting hole.
3. Remove the tank link plug from both of the tanks.

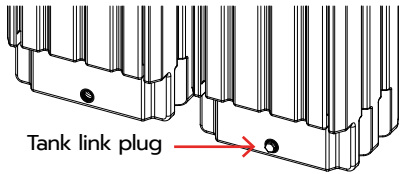

4. Drill a 20mm hole in both tanks in the link plug area avoiding damage to the internal brass threads. Use a vacuum to remove any debris from inside of the tanks.
5. Attach the supplied threaded push-fit connectors to each tank ensuring a watertight seal is made.
6. Position the tanks side by side on a flat level surface capable of supporting the weight of both units when filled.

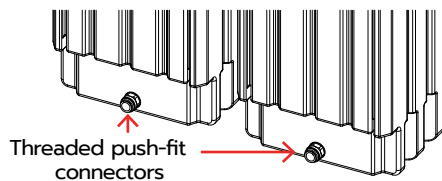

7. Assemble the linking kit as shown below.

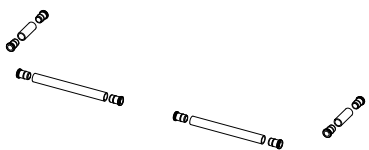

Step 1: pipe inserts should be pushed into each pipe end.

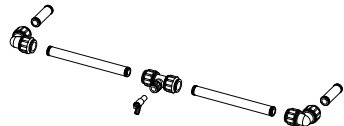

Step 2: pipes and drain plug should be pushed into each push-fit connector as shown, ensuring a watertight fit and that the collars have been tightened.

8. Insert the assembled linking kit into the push fit connectors on the tanks, ensuring a watertight fit. Note, ensure the pipes are fully inserted and that the collar on the push-fit has been tightened.

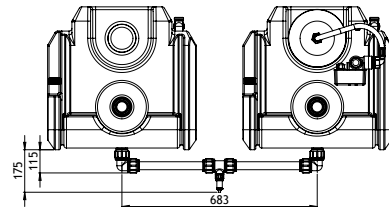
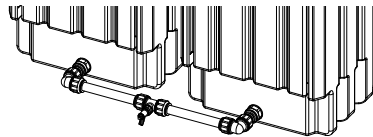

Consider the additional space required for linking the tanks, as shown above.

9. It is important that the mains water inlet is connected to the tank without the pump to ensure a good turnover of water within the tanks.
10. Continue to follow the installation instructions from page 6. Refer to the typical installation diagrams on page 7 for further guidance.

CAT5 TankBoost

There is a CAT5 option available for all tank sizes incorporating a weir type overflow, with a Type AB air gap, providing fluid category 5 backflow protection.

CAT5 Weir Type Overflow

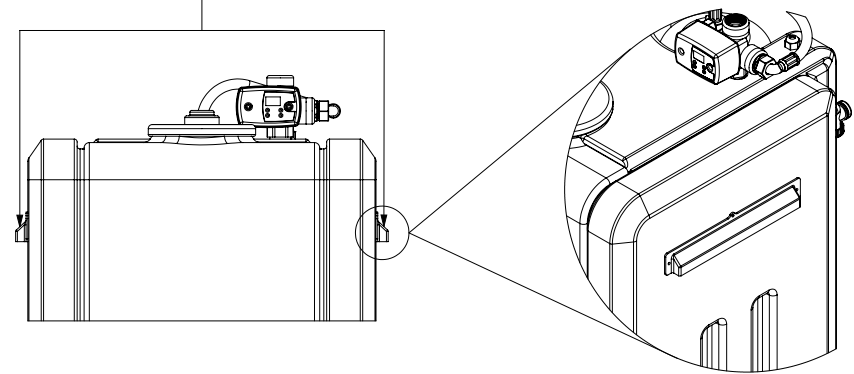

For CAT5 variants, check there is at least a 28mm gap between the level of the water when full and where the water exits the inlet valve. Adjust the float position if necessary – see diagram.

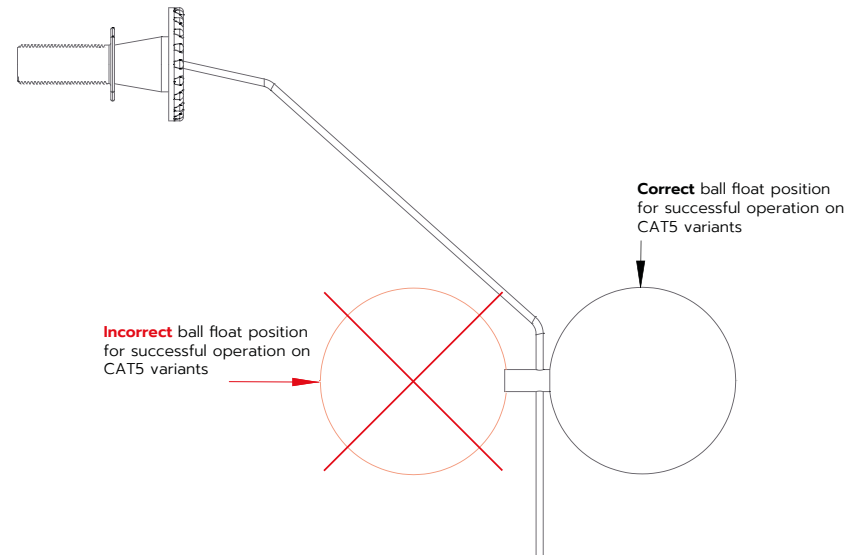

WEEE Directive

Your appliance contains valuable materials which could be recovered or recycled. At the end of the product's useful life please dispose of it at an appropriate civil waste collection point.

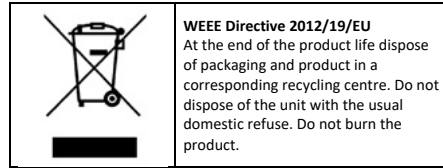

PumpWise and Warranty

Monday – Thursday 8.30am - 4.30pm
Friday 8.30am – 2.30pm

PumpWise is the cornerstone of Salamander's support service to our customers and the means by which our customers are guaranteed:

- **Selection of the right pump for the job**
With more than 30 pumps in our range, the PumpWise team can help you to choose the pump that's most suitable to your specific installation.
- **The avoidance of installation pitfalls**
Due to the technical nature of our products, it is essential that they are fitted according to our installation guidelines. The PumpWise team are available to talk through any installation questions and provide technical support and guidance.
- **Warranty**
TankBoost has a two year warranty.

Our PumpWise commitment

Our PumpWise helpline is here to help you and we aim to provide a support service second to none. Installers and consumers can be sure of a speedy response to requests for technical help, guidance, and advice.

Your warranty

TankBoost comes with a two year warranty. This warranty will operate from the date of purchase and is subject to the installation guidelines being followed correctly (please refer to our installation notes and our Commissioning checklist).

Please complete the warranty registration online at www.salamanderpumps.co.uk or by calling 0191 516 2002.

For further details please contact the PumpWise team:
Telephone: 0191 516 2002
Email: tech@salamanderpumps.co.uk

PLEASE NOTE: Incorrect installation will invalidate the unit warranty. Please fully read the following terms and conditions.

To the installer

Please follow the guidelines for the installation provided in this brochure and call the PumpWise helpline for installation advice. Once installation has been completed and the system has been tested to your satisfaction, please assist the customer by giving them the information needed to complete the online warranty registration. Please note that Salamander are able to provide an onsite service visit which may be chargeable.

Warranty

1. The Scope of the Warranty

SALAMANDER PUMPED SHOWER SYSTEMS LTD ("the company") Warrants subject to the terms and conditions below for the Warranty period(s) specified in paragraph 3 that the Company shall:

Repair or replace free of charge the product(s) specified on the Warranty registration or any component part thereof (together referred to as "the equipment") which shall in the opinion of the Company have proved defective by reason only of the Company's materials or workmanship providing always that the Company shall be under no obligation whatsoever under this Warranty to repair or replace equipment which shall have been misused modified altered or transformed in any way without the consent in writing of the Company or if any component or accessory shall have been replaced by a type not specified by the Company or if the equipment is incorrectly installed or operated or used other than as described in the instruction manual or if any servicing or repair of the equipment shall have been carried out otherwise than by an authorised Company dealer appointed by the Company ("dealer").

The Company's liability under this Warranty is limited to the said repairs or replacement and shall under no circumstances extend to any financial loss or damage including consequential losses alleged to have been suffered by the claimant.

Subject as provided in this warranty and except where the equipment is sold to a person dealing as a consumer all warranties, conditions or other terms implied by law are excluded to the fullest extent permitted by law.

Nothing in this warranty shall exclude liability for death or personal injury caused by the Company's negligence.

2. The Warranty Periods

The Warranty periods referred to in paragraph 1 above are as follows:

- a. TankBoost product manufactured by the Company two years from date of purchase provided the warranty is registered with the Company within 15 days of purchase.
- b. Products supplied by the Company, but not of the Company's manufacture – one year from date of purchase.
- c. The warranty period in respect of any product repaired or replaced under the warranty shall be part of the above period(s) which remain unexpired.
- d. In the event of a claim for repairs or replacement being made under the terms of this Warranty in the circumstances where in the opinion of the Company the defect has not been caused by the Company's materials or workmanship then the Company reserves the right to charge the claimant at its current hourly rates and list prices in respect of any service engineer's time and any replacement of parts.
- e. This Warranty is given in addition to and does not affect your statutory rights as a consumer.
- f. This Warranty is valid and enforceable for equipment purchased and used exclusively in the UK and The Republic of Ireland only.
- g. Where the Company makes a replacement the equipment replaced shall be returned to the Company forthwith and shall become the property of the Company.
- h. No authority has been given to any person, firm or company to vary the terms of this Warranty.

Terms and conditions

This Warranty shall only be enforceable by you if the following terms and conditions have been complied with:

- a That the product has been installed in accordance with the installation instructions, guidance and advice contained within the installation and warranty guide and/or provided by the Salamander help desk.
- b You are the original purchaser of the equipment from a dealer and not an assignee or subsequent purchaser of the equipment.
- c You must evidence the date of purchase by retaining the original invoice from the dealer. Without such evidence the Company reserves the right to reject any such claims under the terms of this Warranty.
- d Within 15 days of delivery of the equipment to you the Warranty is registered with the Company.
- e Within thirty days of discovery of a defect giving rise to liability under paragraph 1 above you give notice thereof in writing to the Company.

Get in touch, we're here to help
call us on 0191 516 2002

Unit 2c Colima Avenue
Enterprise Park West
Sunderland, SR5 3XE

For ROI/EU Customers:
MT Agencies Ireland Ltd
Fearn House, Jamestown Business Park
Jamestown Road, Finglas
Dublin 11, D11 K7TV



Register your warranty

Online at: www.salamanderpumps.co.uk

By phone: 0191 516 2002



**MADE IN
BRITAIN** 

Pump  **wise**